

Lubricate all seals with clean hydraulic fluid, prior to assembly.  
Do not use silicone based lubricants.

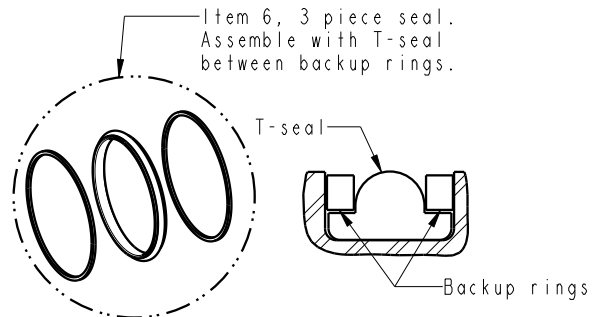

Standard Seal Kit	Fluorocarbon Seal Kit
60-2002-15	6V-2002-14
39-H110-31	39-H110-31
39-0110-48	39-0120-07
39-0010-13	39-0120-14
39-0500-20	39-0500-20

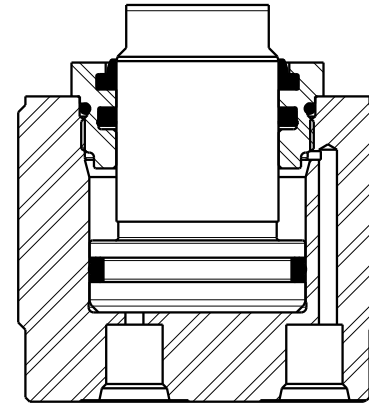
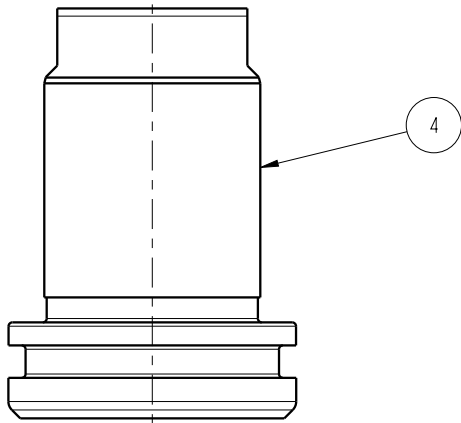
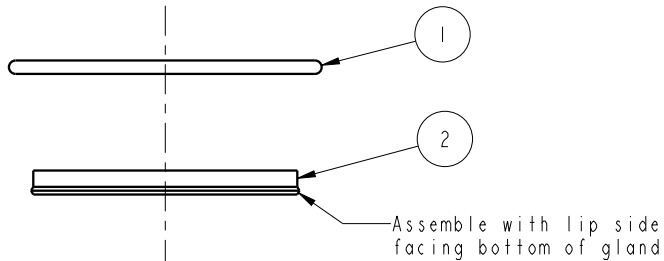
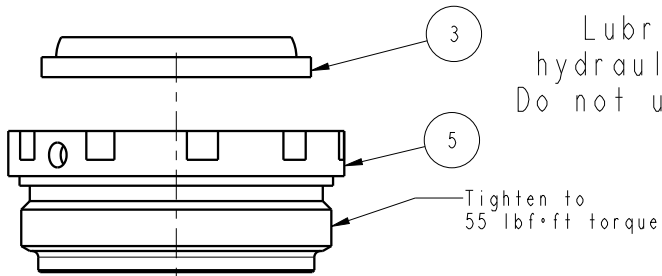
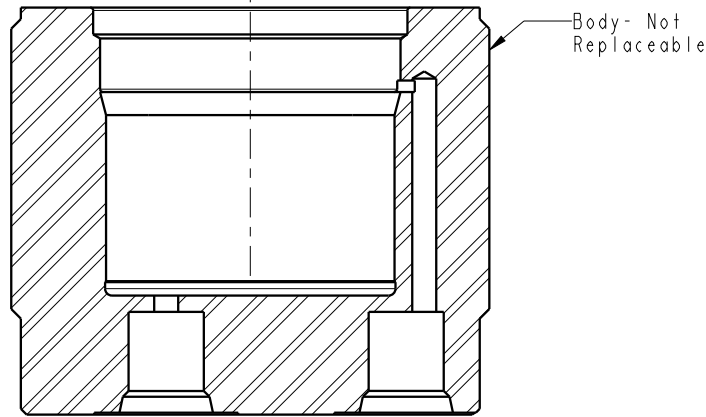

No.	QTY	PART No.	DESCRIPTION
6	1	39H11031	SEAL, T, (1 5/16X5/32XI 1/2)
5	1	82031501	GLAND, CYL, 8800 & 39.9 KN
4	1	82011504	PISTON, CYL, 8800, .5 STRK
3	1	39050020	WIPER, SNAP-IN, (1-1/8)
2	1	39011048	SEAL, LL, (1-1/8 X 1/8 X 1/8 X 1-3/8)
1	1	39001013	O-RING, (-029)

**PARTS LIST**



Model Number  
20-0215-00  
20-0215-00F

ASSY, CYL, TB, 8800, .5 STRK, DA  
SIZE A  
**PL2126**  
REV G

G	5499	RELEASE	NPETERS	9/23/24
REV	IN ACCORDANCE WITH ECN	EFFECTIVE DATE	REVISED BY	DATE
DRW BY:	JACOB	<b>DRAWING STATUS: Released</b>		
DATE:	9/20/96	PRODUCTION APPROVED FOR RELEASED STATUS ONLY		